

THIS DWG. IS SOLE PROPERTY OF NEOMETRIX ENGINEERING PVT. LTD. UNAUTHORISED USE OF THIS DWG. OR MAKING PRODUCT AS PER THIS DWG. WITHOUT OUR PERMISSION OR ANY OTHER MISUSE IS NOT PERMITTED.

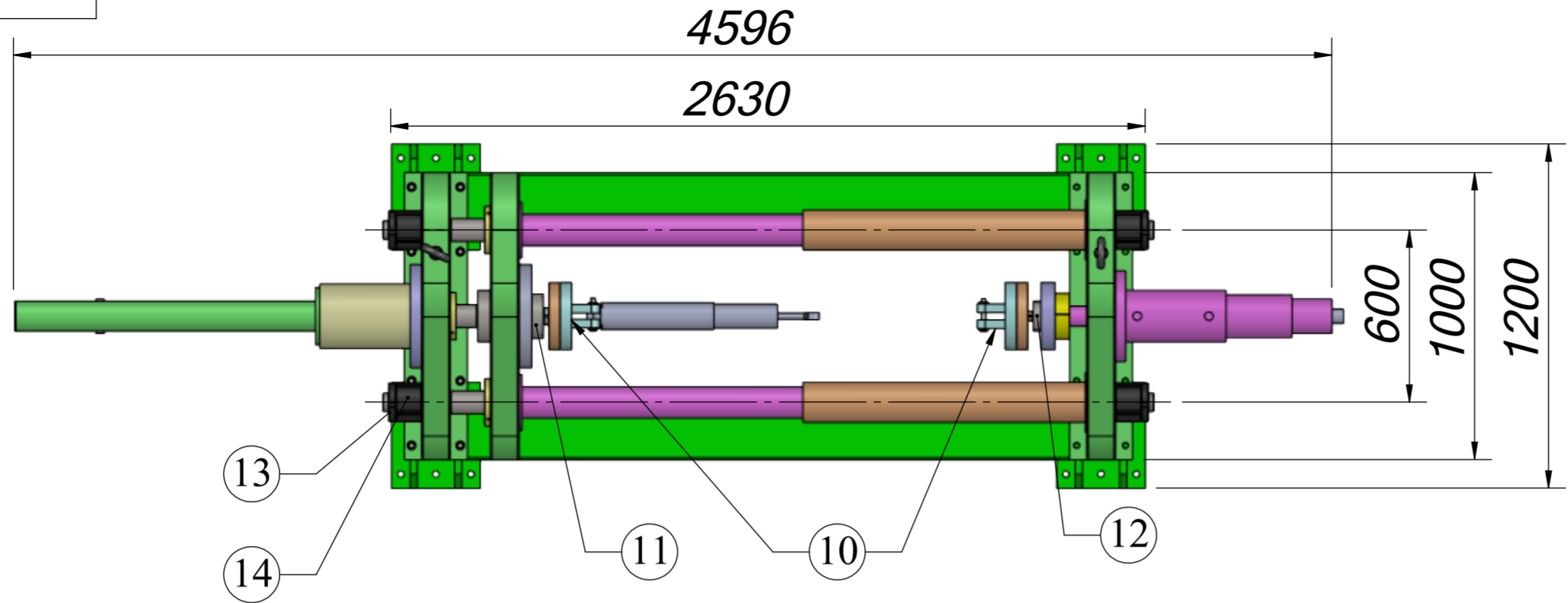

TOP VIEW

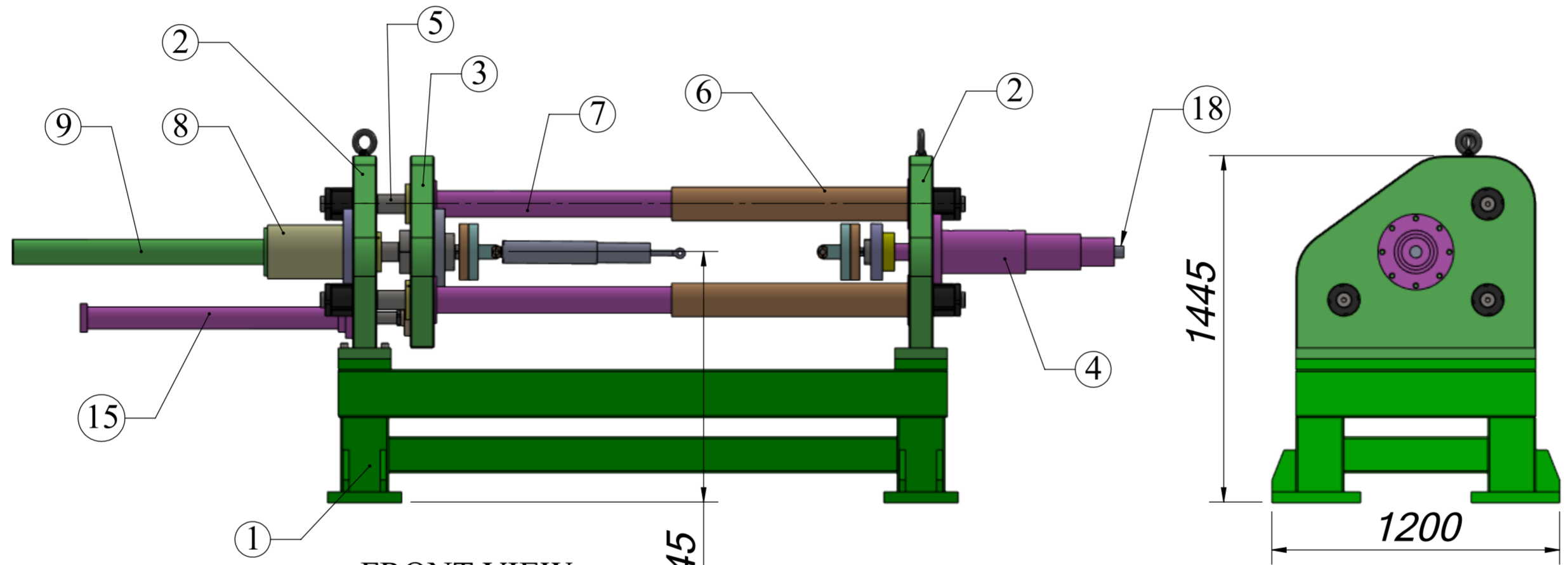

FRONT VIEW

SIDE VIEW

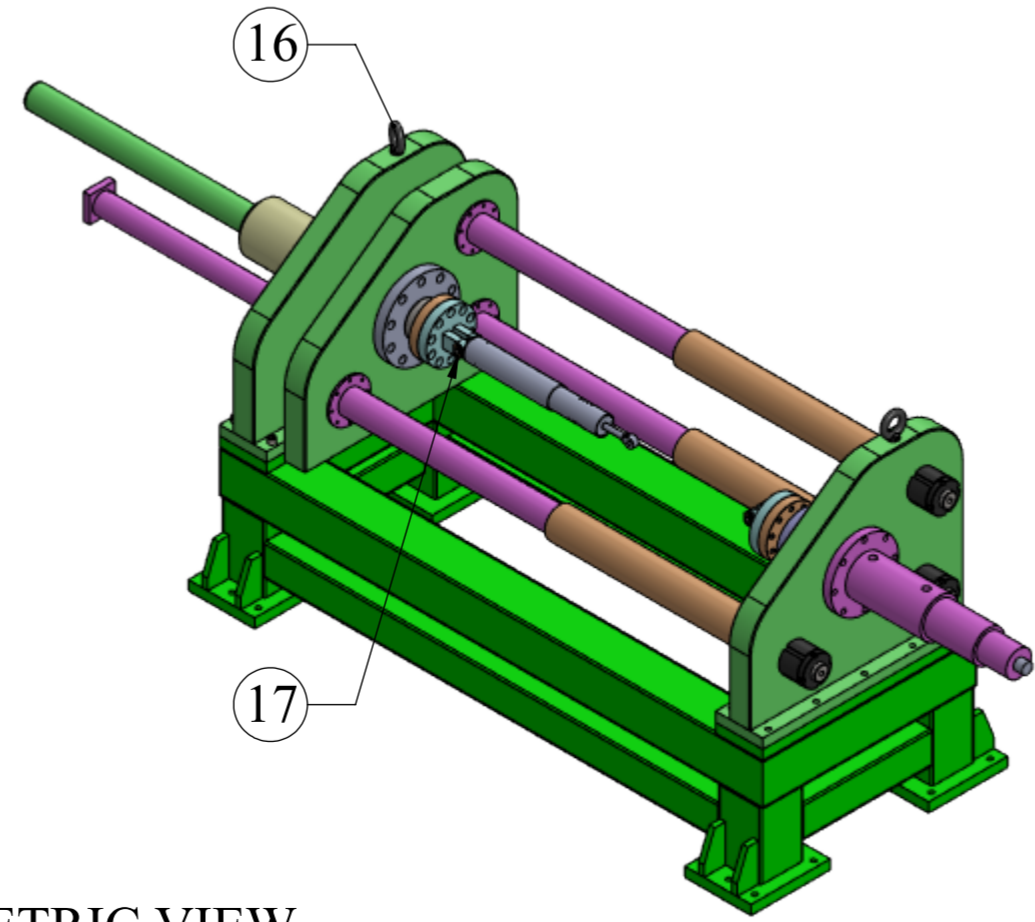

ISOMETRIC VIEW

NOTE:-  
THIS IS TENTATIVE DRAWING, SUBJECT TO CHANGE.

DETAILS

S.No.	ITEM NAME	SPECIFICATION	QTY.
1	Bed	Square Pipe (200x200x5mm)	1
2	Fixed Beam	1000x845x220 mm	2
3	Adjustable Plate	1000x800x100 mm	1
4	Servo Actuator	Bore dia. 130mm, Rod dia. 70mm, Stroke: 250 mm	1
5	Guide Rod	∅ 80x2690 mm	3
6	Fixed Cover	∅ 140x1000 mm	3
7	Moving Cover	∅ 110x1030 mm	3
8	Locking Device	Load cap. 25 Ton( Positive Locking), Work at pressure: 100 bar	1
9	Rod Cover	∅ 105x1065 mm	1
10	Clevis	∅ 235x190 mm	2
11	Load Cell	25 Ton	1
12	Load Cell	1 Ton	1
13	Nut	M65x3P	6
14	chuck Nut	M65x3P	6
15	Hydraulic Cylinder for moving plate	Bore dia.: 80mm, Rod dia.: 50mm, Stroke: 925mm	1
16	Lifting Hook	Eye bolt (M30)	2
17	Locking Pin	∅ 35x160 mm	2
18	Absolute Linear Digital Encoder	Scale: 250mm, Make: MTS	1

NOTE:-

1. ALL DIMENSIONS ARE IN MM.

		NEOMETRIX ENGINEERING PVT LTD E-148, SECTOR 63, NOIDA, UP-201301 Tel No.: 0120 4500800 Fax No.: 0120 4500888 E-mail: contact@neometrixgroup.com Design Dept.: design@neometrixgroup.com	
		QA No.	Cross Ref Doc No.:
TITLE	SNUBBER TEST FACILITY	Customer Dwg Ref No.	
SUB-TITLE	GA DRAWING	NOTE :	
SRS CODE	A3798		
CUSTOMER	--		
END USER	--		
TD/PO. No.	--	DATED	
PROJECTION	DRWN	M.F	25/10/2023
CHK.	M.A	25/10/2023	SIZE SCALE SHEET No OF
APPR.	S.P.S	25/10/2023	A3 NFS 01 01
		NEO DWG No.	
		T-DAP-A3798-GADWG-STF	
		REV	
		01	

THIS DWG. IS SOLE PROPERTY OF NEOMETRIX ENGINEERING PVT. LTD. UNAUTHORISED USE OF THIS DWG. OR MAKING PRODUCT AS PER THIS DWG. WITHOUT OUR PERMISSION OR ANY OTHER MISUSE IS NOT PERMITTED.

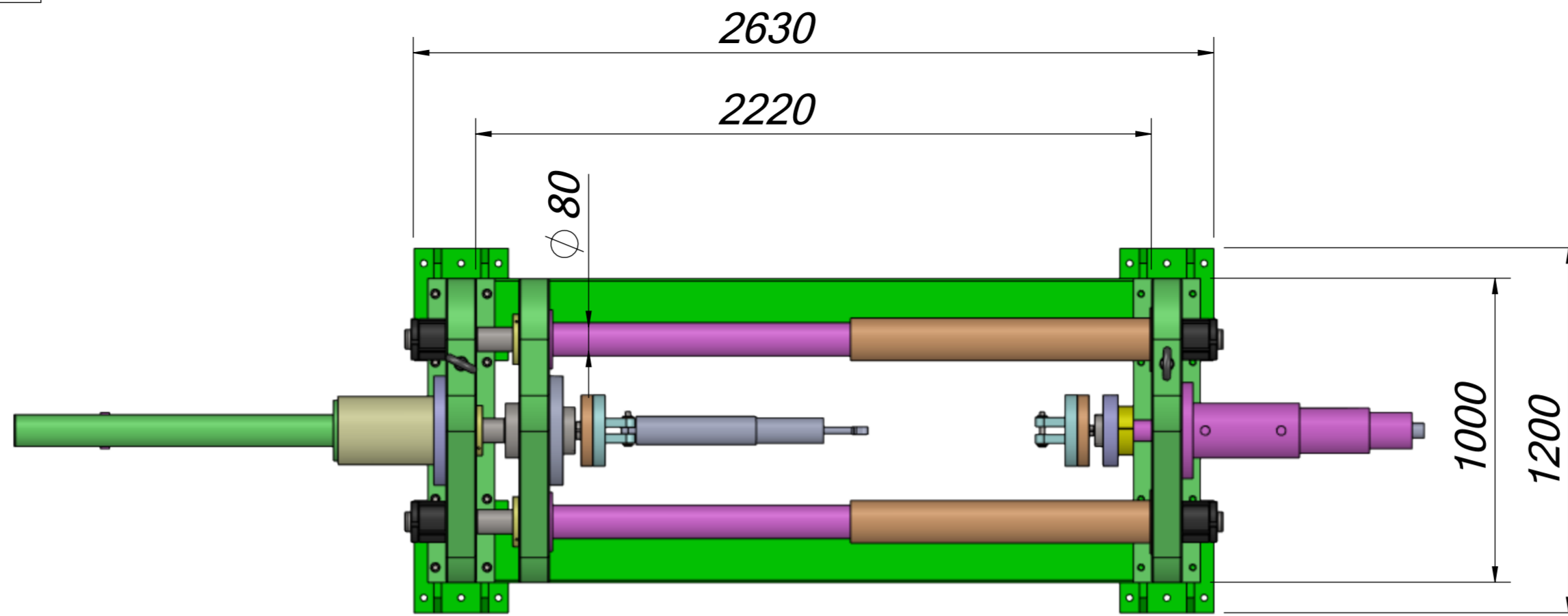

TOP VIEW

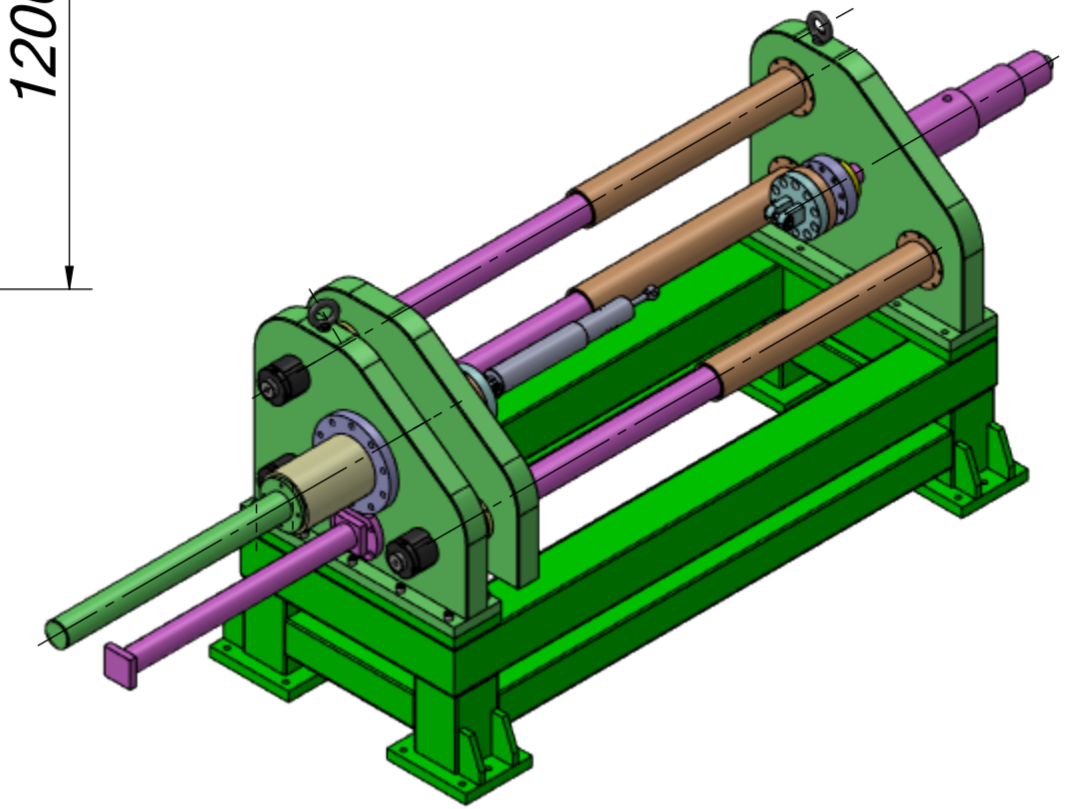

ISOMETRIC VIEW

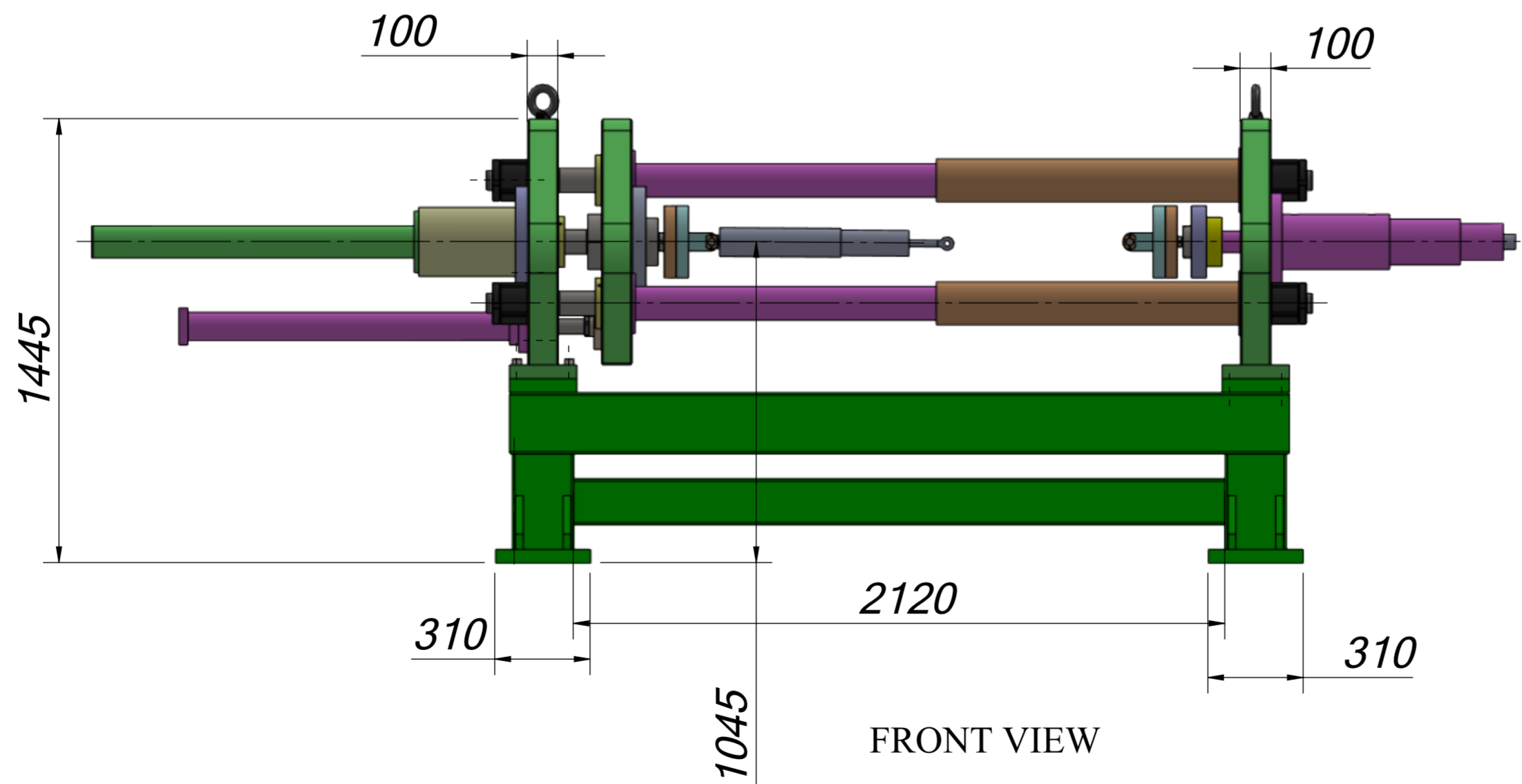
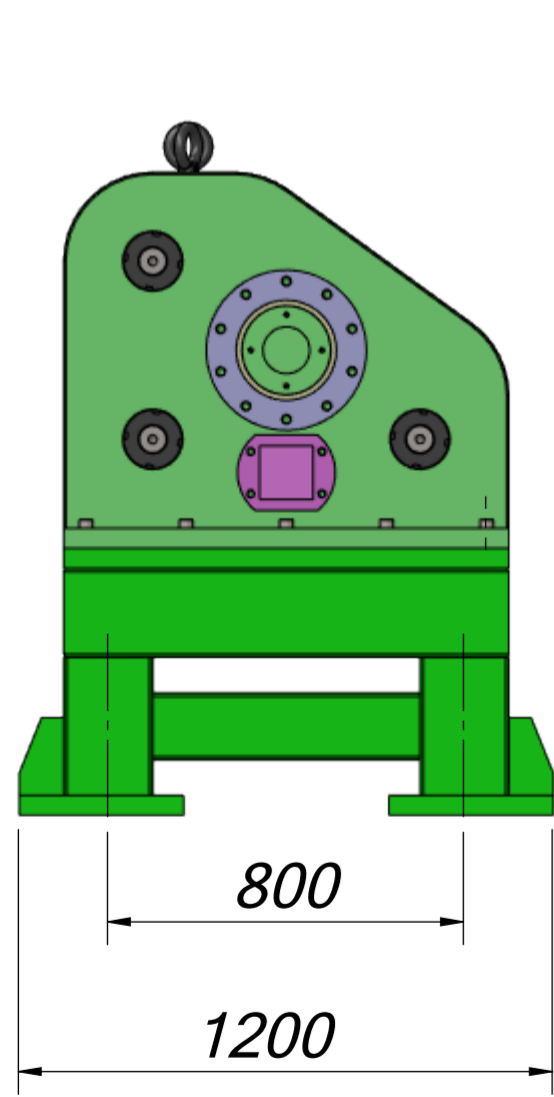

FRONT VIEW

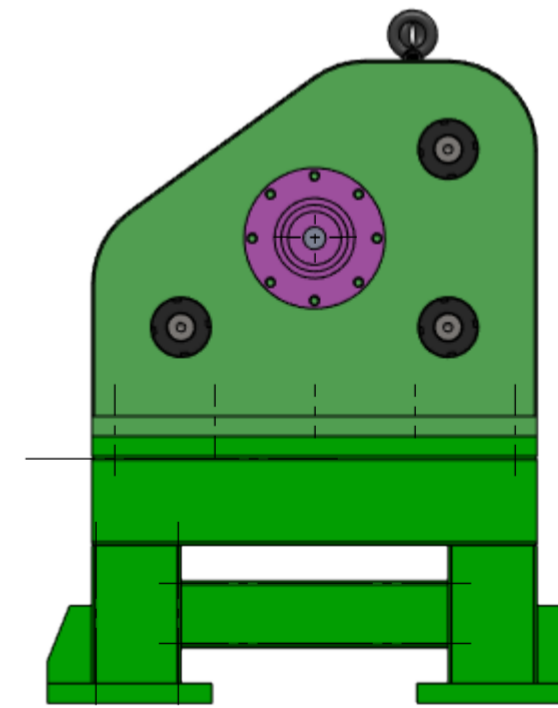

**NOTE:-**

1. ALL DIMENSIONS ARE IN MM.
2. TOTAL WEIGHT- 3300 KG.

						NEOMETRIX ENGINEERING PVT LTD E-148, SECTOR 63, NOIDA, UP-201301 Tel No.: 0120 4500800 Fax No.: 0120 4500888 E-mail: contact@neometrixgroup.com Design Dept.: design@neometrixgroup.com																			
						TITLE		SUB-TITLE		SRS CODE		CUSTOMER		END USER		TD/PO. No.		DATED		SHEET No. OF		NEO DWG No.		REV	
--		GA DRAWING		A3798		--		--		--		--		25/10/2023		A3		NFS		01/01		T-DAP-A3798-GADWG-STF		01	