

THIS DWG. IS SOLE PROPERTY OF NEOMETRIX ENGINEERING PVT. LTD. UNAUTHORISED USE OF THIS DWG. OR MAKING PRODUCT AS PER THIS DWG. WITHOUT OUR PERMISSION OR ANY OTHER MISUSE IS NOT PERMITTED.

DETAILS	
S.No.	ITEMS
1	CHASSIS
2	CANOPY
3	OIL FREE COMPRESSOR
4	DIESEL GENERATOR (DG)
5	MOISTURE SEPARATOR
6	PRE-FILTER
7	REFRIGERATION AIR DRYER
8	DESICCANT DRYER
9	FINE FILTER
10	TANK
11	SUSPENSION SYSTEM
12	JACK SCREW
13	RADIAL TYRE
14	TOW BAR FRAME

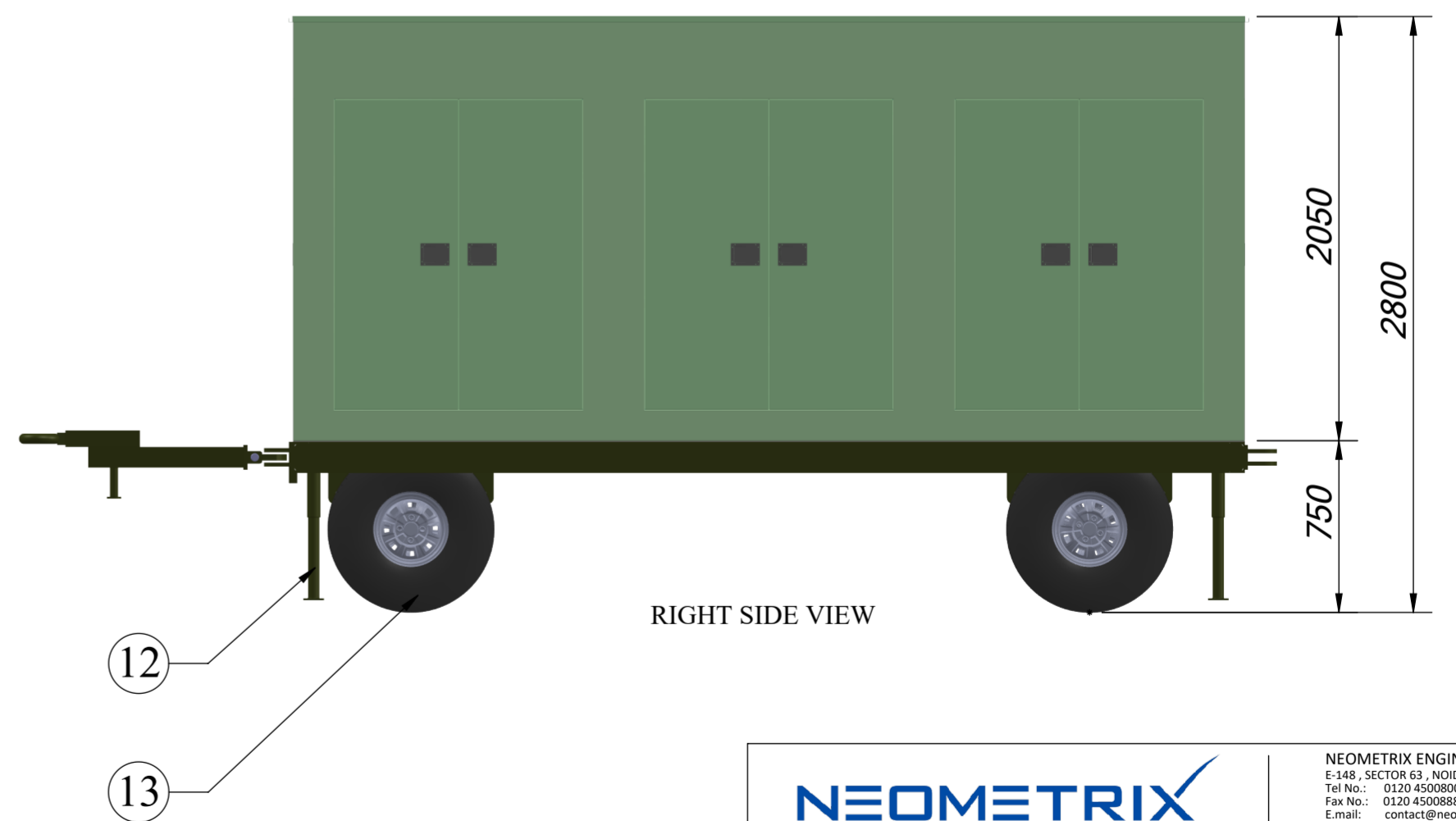
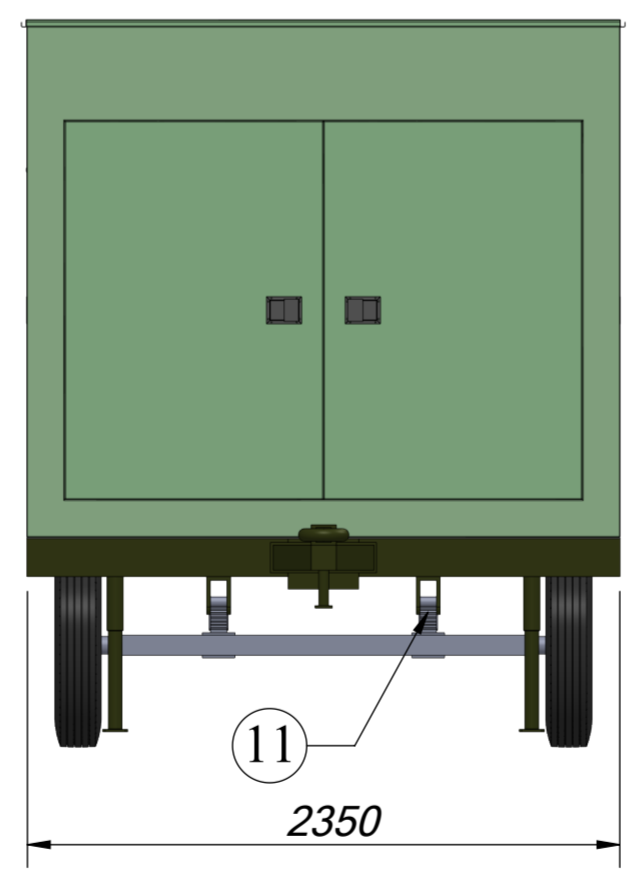
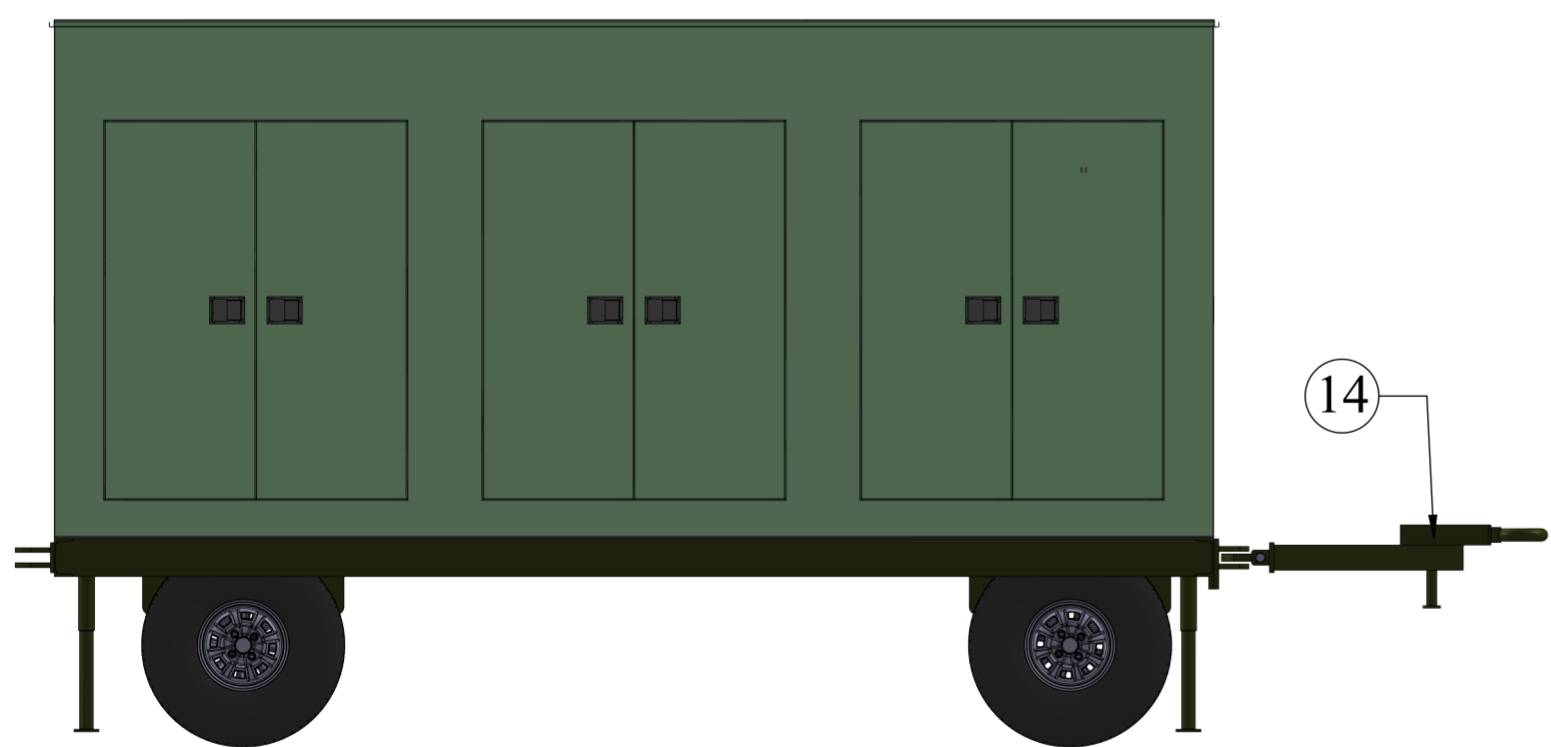
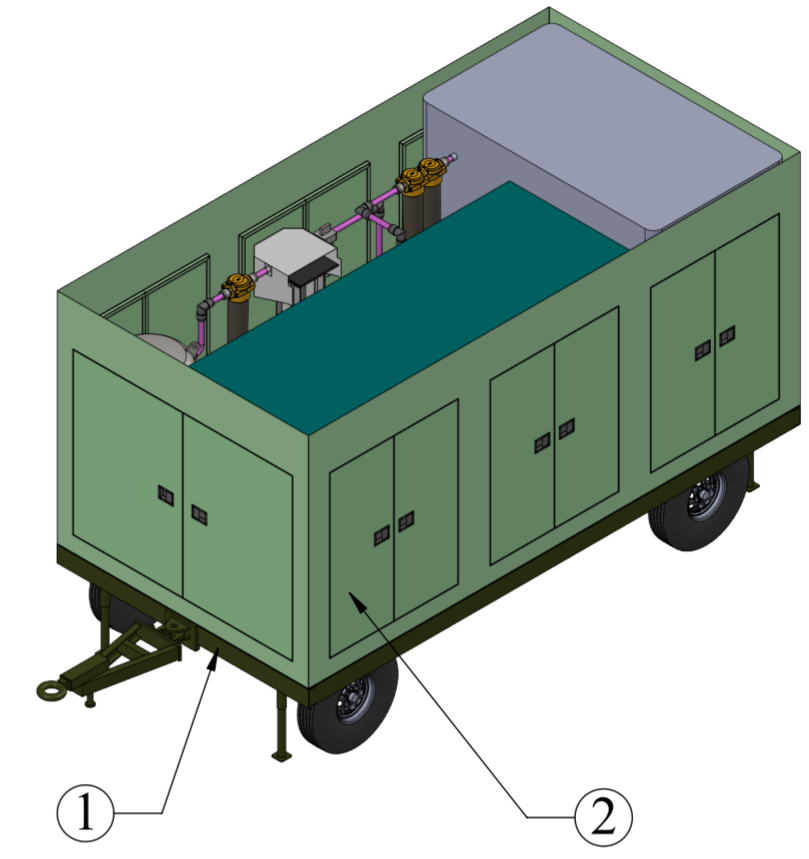
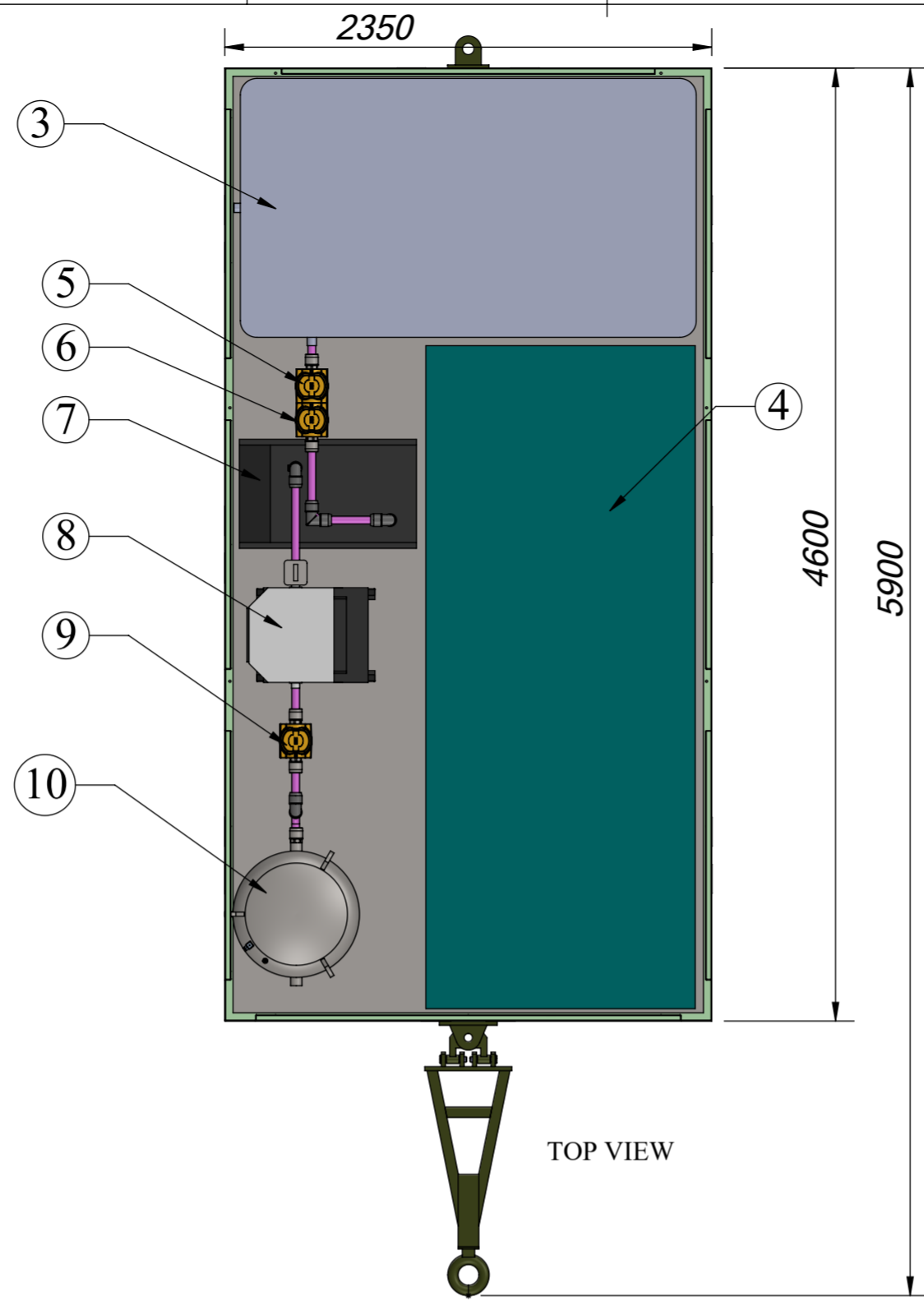
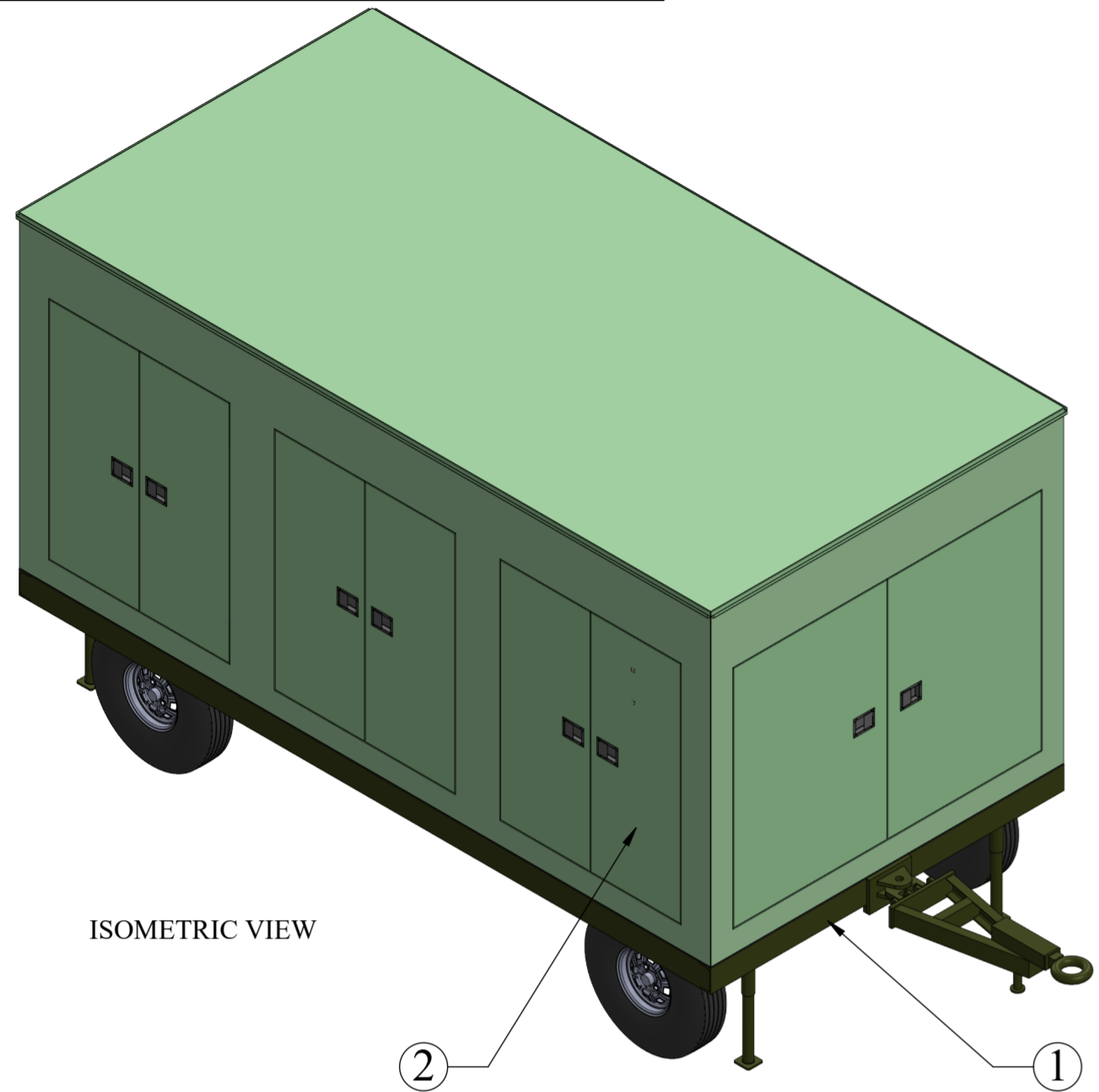

NOTE:-  
 1. ALL DIMENSIONS ARE IN MM.  
 2. GROUND CLEARANCE- 250 MM (MIN.)  
 3. THIS IS TENTATIVE DRAWING, SUBJECT TO CHANGE.

<b>NEOMETRIX</b>		NEOMETRIX ENGINEERING PVT LTD E-148, SECTOR 63, NOIDA, UP-201301 Tel No.: 0120 4500800 Fax No.: 0120 4500888 E-mail: contact@neometrixgroup.com Design Dept.: design@neometrixgroup.com	
TITLE	OXYGEN CHARGING & DISTRIBUTION SYSTEM (UGSS-02)		
SUB-TITLE	G.A DRAWING-OIL FREE AIR COMPRESSOR TRAILER		
SRS CODE	A3128		
CUSTOMER	INDIAN AIR FORCE		
END USER	INDIAN AIR FORCE		
TD/PO. No.	--	DATED	
PROJECTION	DRWN	M.F	15/03/2024
	CHK.	S.K	15/03/2024
	APPR.	S.P.S	15/03/2024
SIZE	SCALE	SHEET No	OF
A3	NFS	01	01
NEO DWG No.			REV
T-DAP-A3128-GA DRAWING			00