

THIS DWG. IS SOLE PROPERTY OF NEOMETRIX ENGINEERING PVT. LTD. UNAUTHORISED USE OF THIS DWG. OR MAKING PRODUCT AS PER THIS DWG. WITHOUT OUR PERMISSION OR ANY OTHER MISUSE IS NOT PERMITTED.

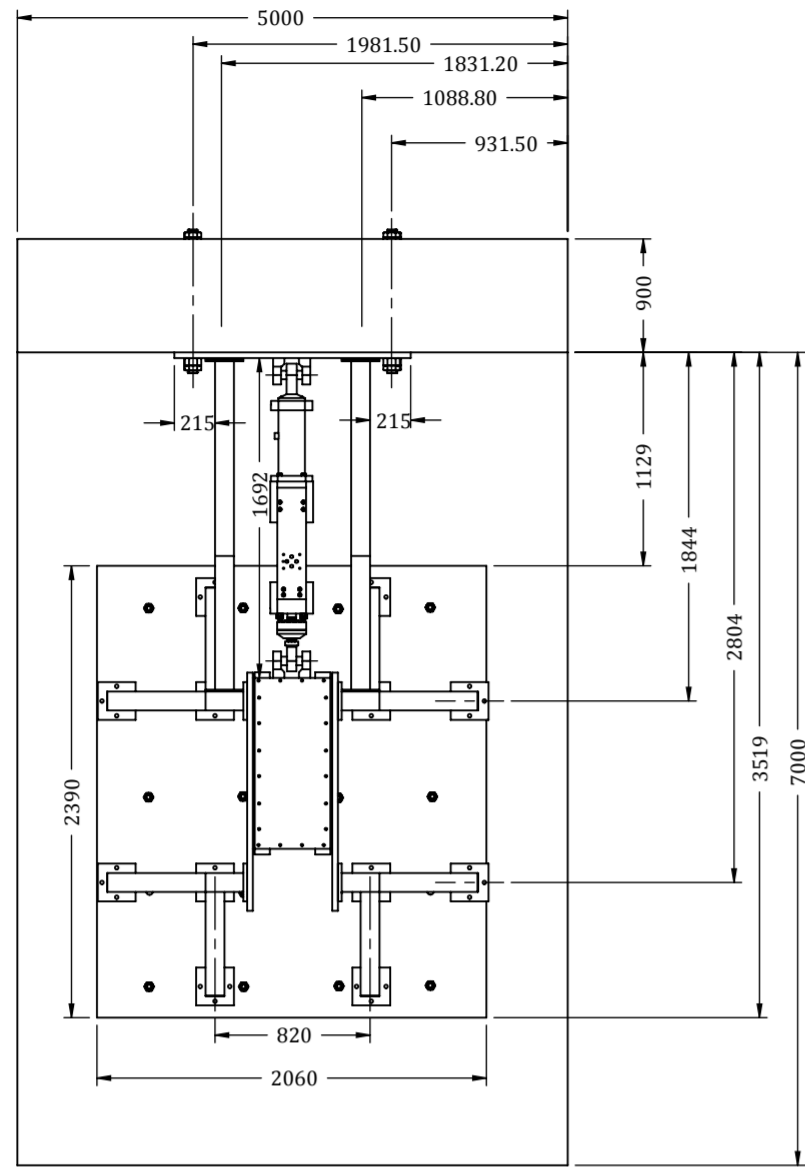

TOP VIEW
(SCALE 1 : 40)

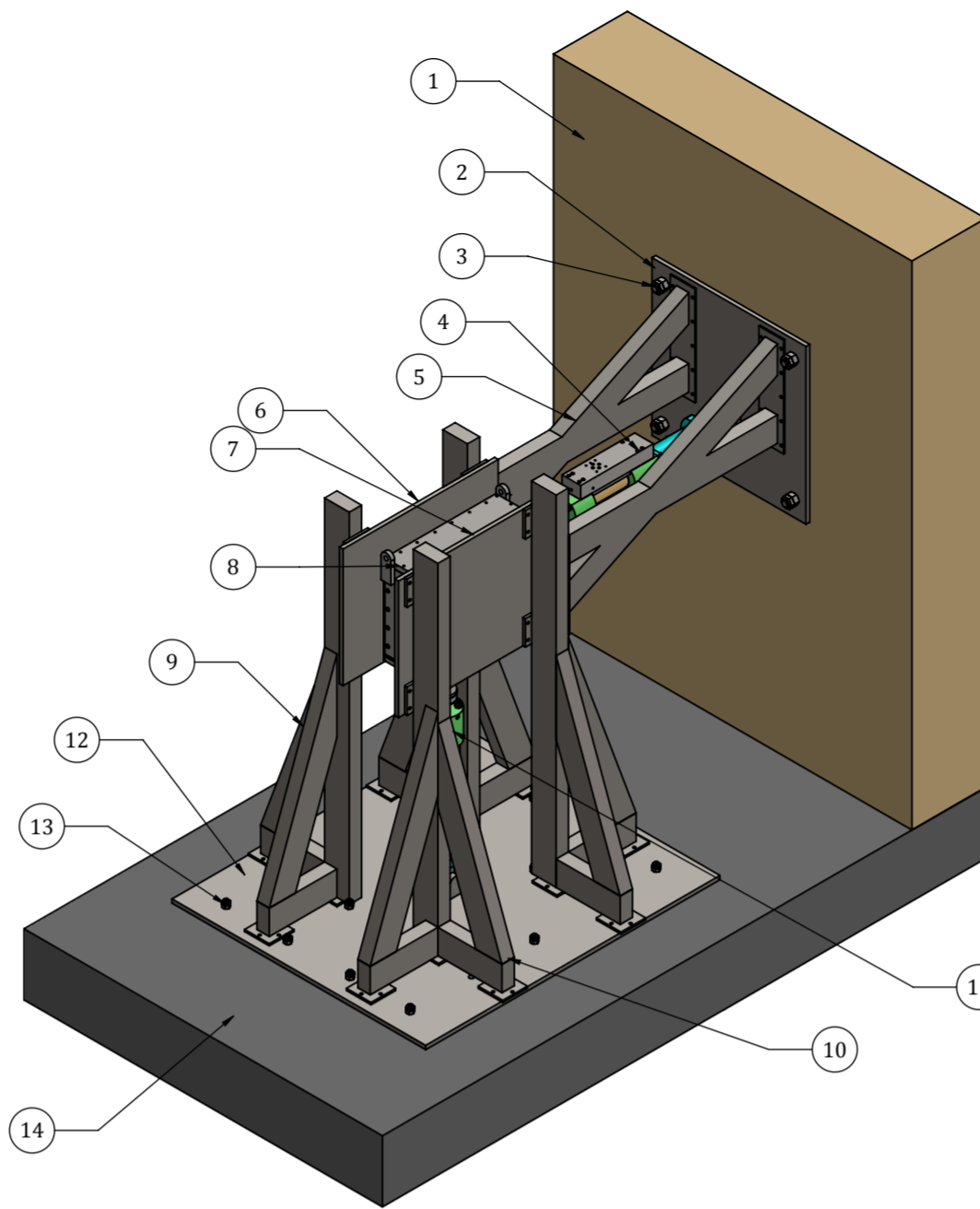

ISOMETRIC VIEW
(SCALE 1 : 40)

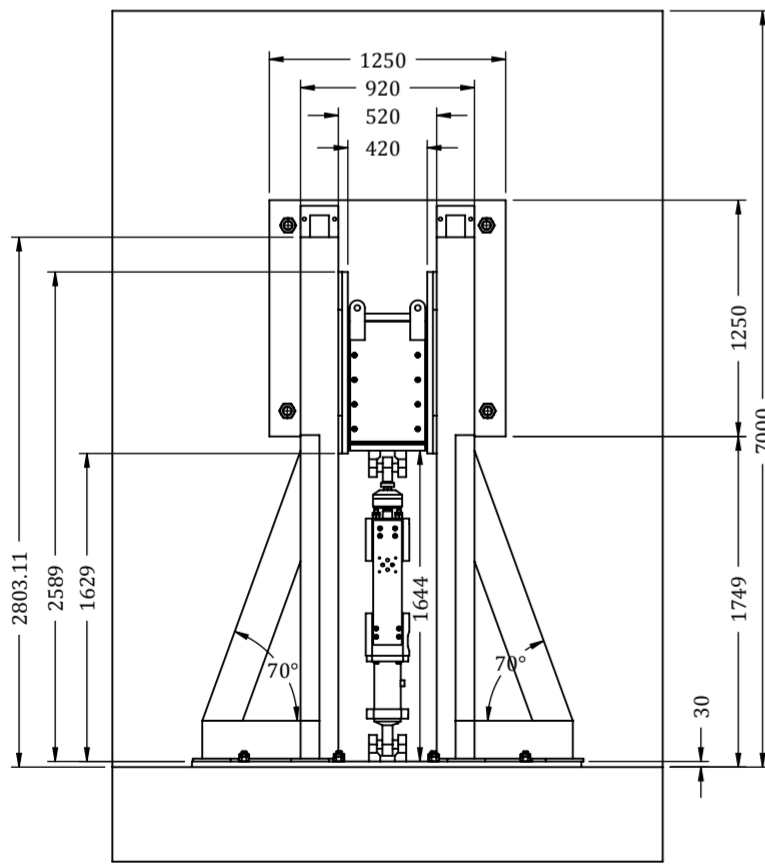

FRONT VIEW
(SCALE 1 : 40)

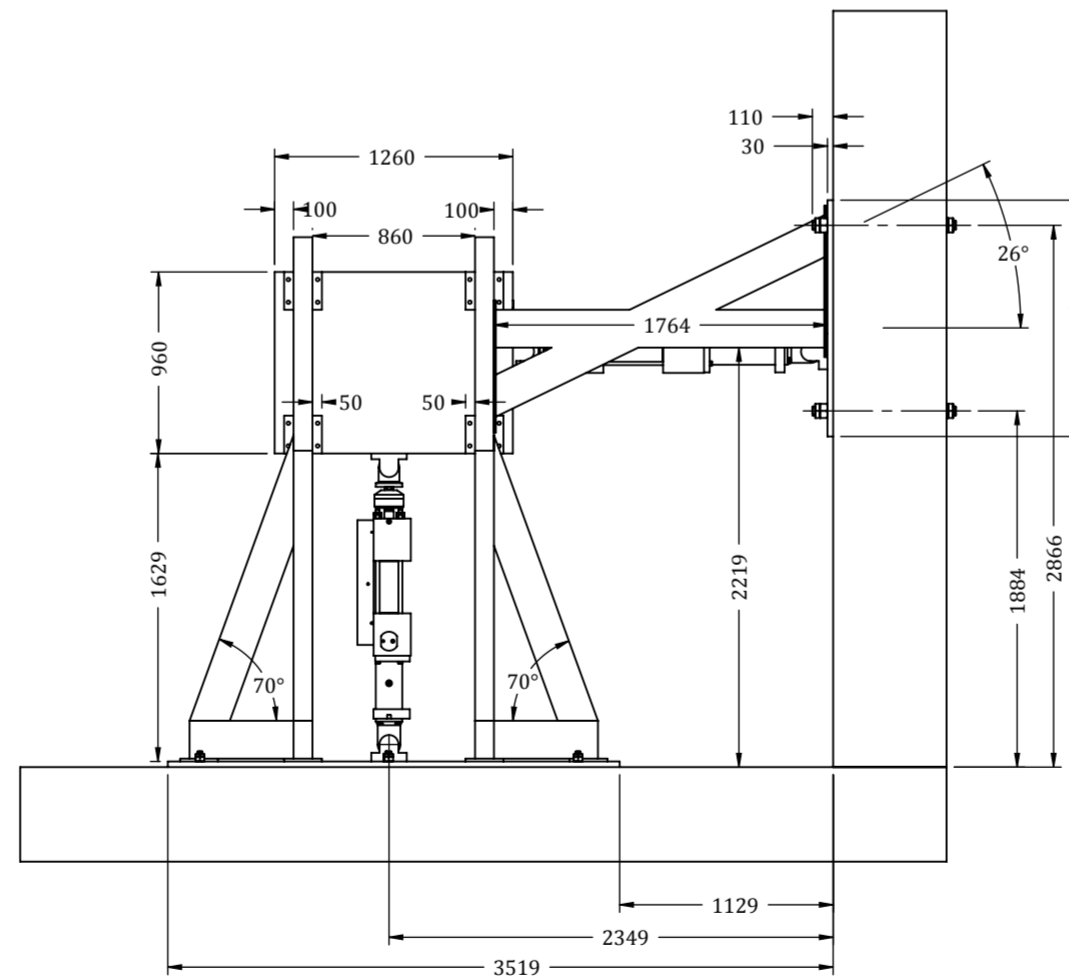

SIDE VIEW
(SCALE 1 : 40)

ITF ASSEMBLY WITH BOTH ACTUATORS

NOTES :

- All dimensions are in mm, until and unless defined
- Remove all burs and sharp edges after machining
- Remove all sharp edges by radius R0.5

DESCRIPTION TABLE					
S.No.	Name	Description	Material	Unit Weight	Qty
1	Shear Wall	7m Height, 5m Long and 900mm Wide Shear Wall	Concrete	--	-
2	Shear Wall Plate	30mm thick PLate, 1250(L) x 1250(H), with 4 nos of Tie Bolt, for Mounting of Horizontal Actuator	MS	370 kg	1 no
3	Shear Wall Tie Bolt	M48x5x1200mm Stud with double ended Nut with Lock Nut	MS	14 kg	4 nos
4	Horizontal Actuator	Linear Horizontal Hydraulic Actuator with all component mounting on it, with Servo Valve, Position transducer and Pressure Transmitter, with stroke of 300mm	--	--	1 no
5	Horizontal Support Frame	200x100x5mm Rec Pipe structure for transferring reaction to the shear wall	MS	105 kg	2 nos
6	Antifriction Guide Left Plate	30mm thick, 1260(L) x 960(H), for guide to the inertial mass left side	MS	290 kg	1 no
7	Antifriction Guide Right Plate	30mm thick, 1260(L) x 960(H), for guide to the inertial mass right side	MS	290 kg	
8	Inertial Mass	904(L)x440(W)x725(H), Inertial Mass (box) with Antifriction Material (GSM) both the left and right side for making zero friction with antifriction guide plate	MS & GSM	640 kg	1 no
9	Inertial Test Frame Left Structure	200x100x5mm Rec Pipe structure for structural frame left side	MS	350 kg	1 no
10	Inertial Test Frame Right Structure	200x100x5mm Rec Pipe structure for structural frame right side	MS	350 kg	1 no
11	Vertial Actuator	Linear Vertical Hydraulic Actuator with all component mounting on it, with Servo Valve, Position transducer and Pressure Transmitter, with stroke of 200mm	--	--	1 no
12	Strong Floor Pate	2390(L) x 2060(W), 30mm thick Strong Floor Plate for transferring all the vertical load to Strong Floor, mounted with M30 tie bolt	MS	1170 kg	1 no
13	Strong Floor Tie Bolt	M30x3.5mm, Length 150mm, with lock nut	MS	2 kg	16 nos
14	Strong Floor	7m Long, 5m Wide Strong Floor with M30 Insert 150mm deep pull out force of 10 ton per anchor	Concrete	--	--

		NEOMETRIX ENGINEERING PVT LTD E-148, SECTOR 63, NOIDA, UP-201301 Tel No.: 0120 4500800 Fax No.: 0120 4500888 E-mail: contact@neometrixgroup.com Design Dept.: design@neometrixgroup.com	
TITLE	HYDRAULIC POWER PACK AND ACTUATOR SYSTEM		
SUB-TITLE	ITF ASSEMBLY WITH BOTH ACTUATORS		
SRS CODE	A1637	Type your text	
CUSTOMER	Logo		
END USER	Logo		
TD/PO. No.	237687	DATED	18/12/2018
PROJECTION	DRWN	SIRSENDU	18/03/2019
CHK.	P.S	18/03/2019	
APPR.	S.P.S	18/03/2019	
SIZE	SCALE	SHEET No	OF
A2	NFS	01	01
NEO DWG No.			REV
T-PED-A1637-GADWG-ITF			01