

DAMPER TEST BENCH



Damper test bench is a high performance test equipment to test the damper assembly of the main HSU unit. Testing to be perform to check the Differential pressure creating capacity of the damper assembly.

Description: The Damper assembly have the main purpose of creating differential pressure within the HSU unit. Damper assembly creates the partition between hydraulic oil filled in bottom part of main cylinder. It absorbs the shock and jerks of the K9 VAJRA Tank and ensure smooth rebound and jounce movement.

Overview: Damper test bench has the cage to assemble the Damper in it. Pressure of upto 150 bar and flow upto 200 LPM is provided on both side of the cage to check the JOUNCE and REBOUNCE characteristics of the damper assembly. Meanwhile, graph of pressure difference V/s flow is plotted and Test report is generated in the end of test.

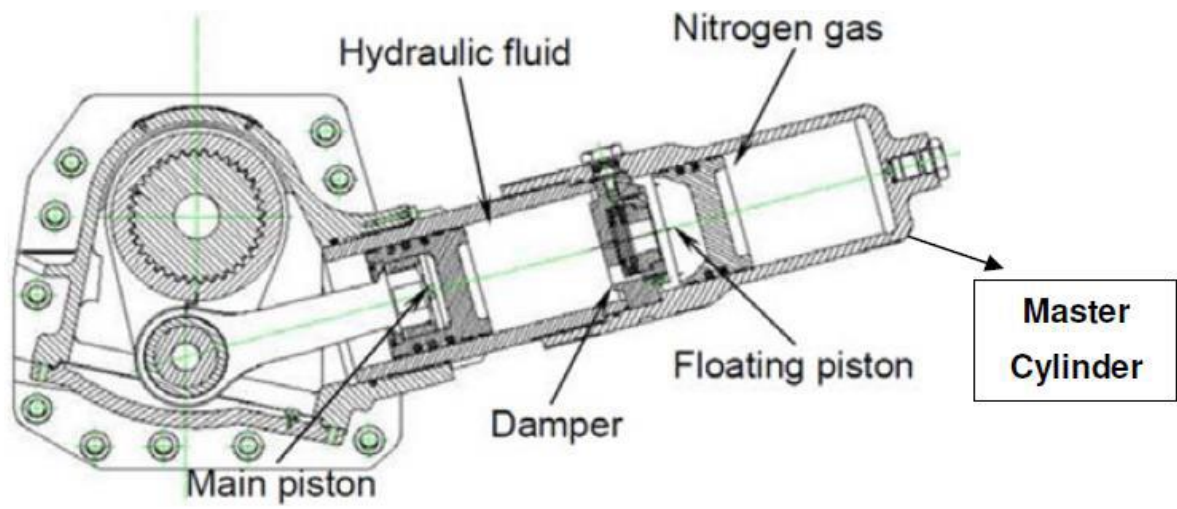

REPORTS TO BE GENERATED BY DAQ SYSTEM

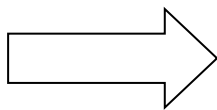

REBOUND

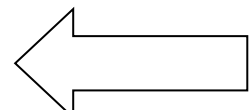

JOUNCE

- JOUNCE

S NO.	Flow(lpm)	Acceptable Pressure Drop Across Damper(bar)
1	50	72.8-23.5
2	90	115.8-76.1
3	110	117.2-100.4
4	200	131.0-105.1

- REBOUND

S NO.	Flow (lpm)	Acceptable Pressure Drop Across Damper(bar)
1	60	76.4-33.3
2	90	81.7-66.9
3	200	93.7-80.3

DIAGRAMMATIC REPRESENTATION

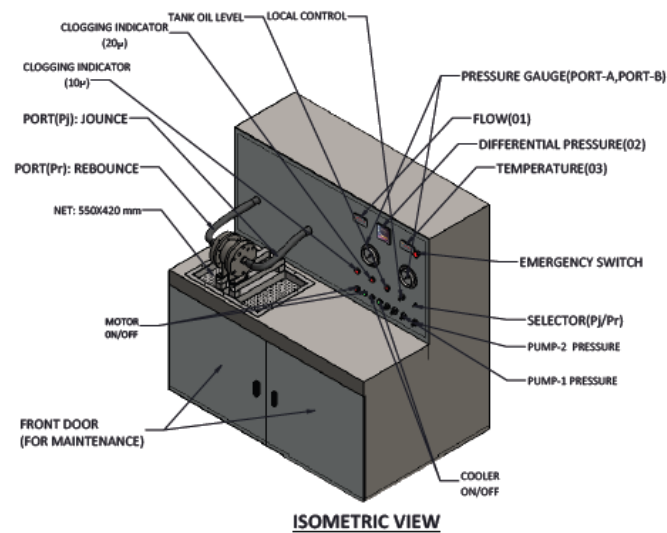

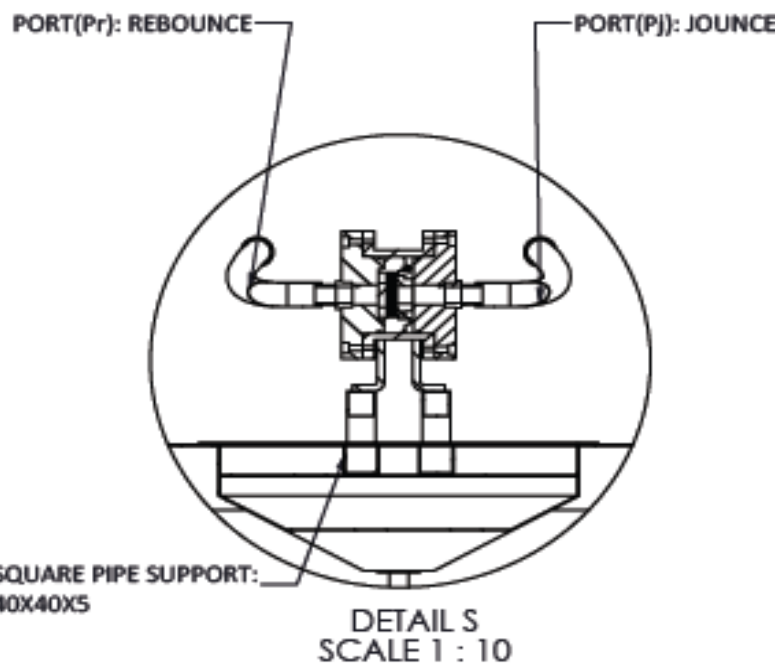
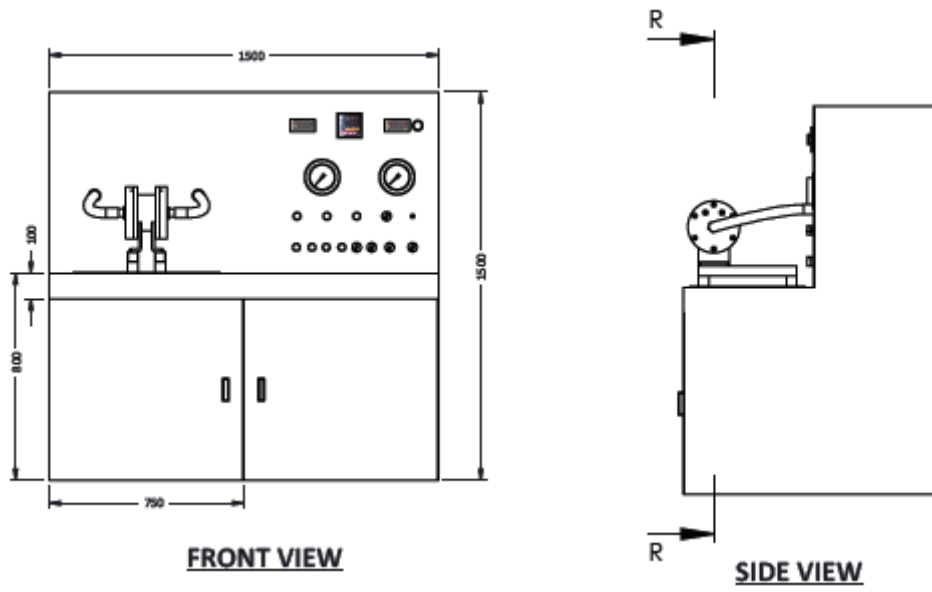

WORKING OF THE SYSTEM

Damper test bench contains three part:

- **Power Pack**: Damper system power pack have two 40 HP motor with external gear pump arrangement of 110 lpm of flow each. Combined flow of 220 lpm is provided by the power pack. Pressure gauge with safety loading- unloading valve is provided on the pressure pack. Pressure limit can be set through this system to ensure full safety from pressure pack. In-line air cooled oil cooling system is provided on the system. 200 liter tank is provided for oil storage equipped with level switch, temperature transmitter, temperature gauge, filler breather, tank top filter and level gauge. High pressure filter of 10 micron filter element is provided to ensure proper cleaning of the system.
- **Damper Panel**: pressure line of the system goes directly to the panel manifold with a hose of parker make. Manifold is connected with manual pressure gauges and pressure transmitter for both side of the damper cage. Pilot operated direction control valve (ng25) is provided in the system to ensure proper connection of A to B and vice versa. Rexroth D.C valve is operated by solenoid operated pilot valve.
- **VFD PANEL** : This panel have ABB variable frequency drive with flow regulator which can control the RPM to the motor and subsequently regulates the flow. Single high performance drive is used to ensure the rotation of the motor is clockwise and other is anticlockwise.

PROCEDURE FOR OPERATION

Before operating the test bench operator must ensure:

1. Open the hose fitting of the damper cage from one side with proper size spanner.
2. Open the Allen bolt of M20 from this side.
3. Put two Allen bolt of M20 in the threaded holes to take out the cage lid easily.
4. Place the damper component assembly inside the cage, make sure all O-rings are there in place.
5. Place the lid back again and tighten every bolt properly. Make sure the hose fitting is tighten to it. **(Arrest all leakage).**

Manual Procedure:

1. Switch on the MAINS supply from the VFD Panel.
2. Switch off the emergency stop and press the motor on button.
3. Engage A to B condition to Test jounce condition.
4. Engage both loading valves(**make sure red light gets ON on both the manifold**).
5. Increase the flow from the flow regulator and set the flow at desired value of the test.
6. Check for the pressure difference at different flow value.
7. After the test in one direction of jounce, engage the B to A condition and check for the rebound test.
8. Again increase the flow and set the value according to the test. **(please refer to the test table on pg. 21).**
9. Check for the pressure difference and match with the table.
10. Slowly make the flow value to zero and switch off the motor supply followed by switching off the main supply.

Automatic Procedure:

1. Switch on the main supply from the VFD panel
2. Switch off the emergency stop.
3. Switch the knob of LOCAL/DAQ to DAQ.
4. Switch on the UPS>industrial computer.
5. From the main screen of the compute go to the Lab view interface. Below screen will appear.

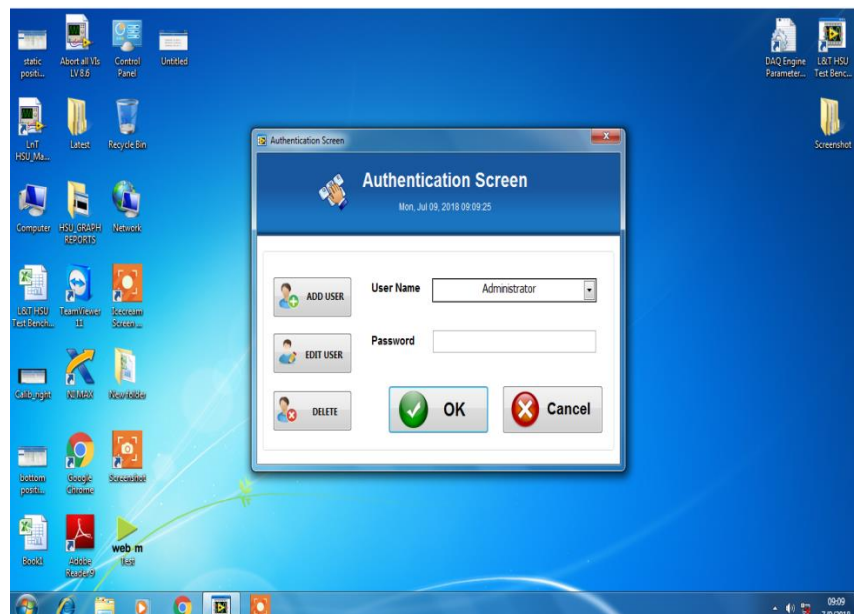

6. Put your username and password>click OK. Below screen will appear.

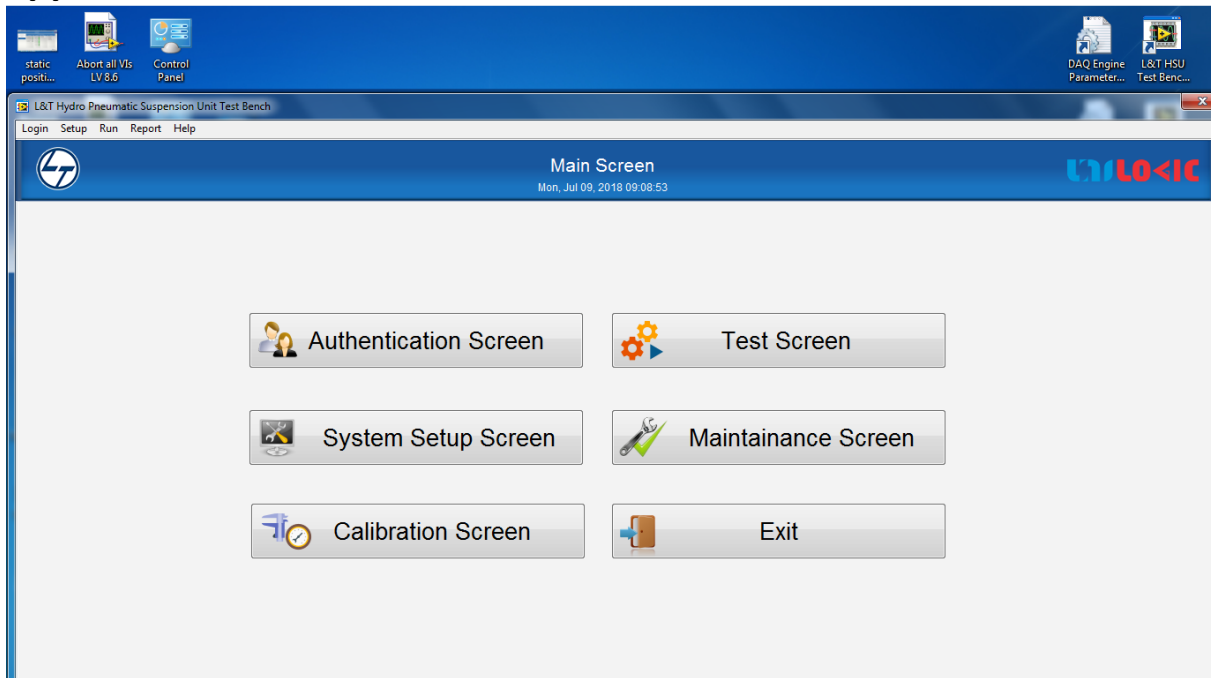

7. Choose the option of DAMPER TEST>enter Unit part number>Unit serial number>test pressure (bar)>Flow (lpm).Click OK. Below screen will appear.

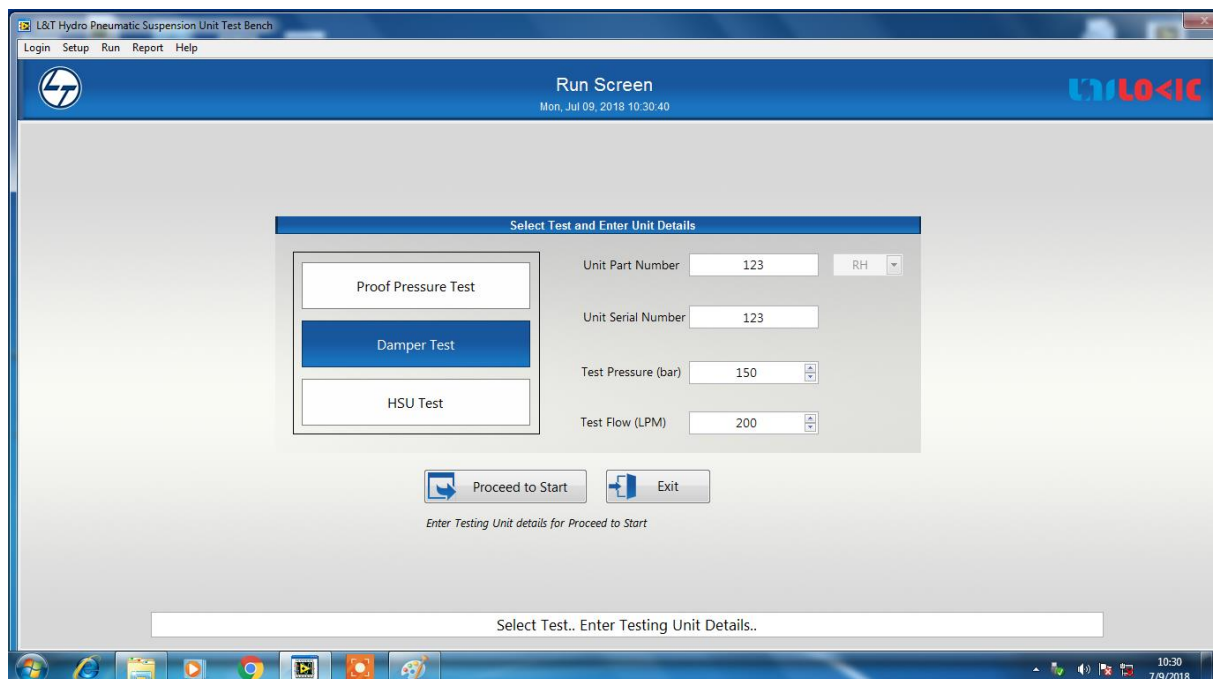

- Choose the option of DAMPER TEST>enter Unit part number>Unit serial number>test pressure (bar)>Flow (lpm).Click OK. Below screen will appear.

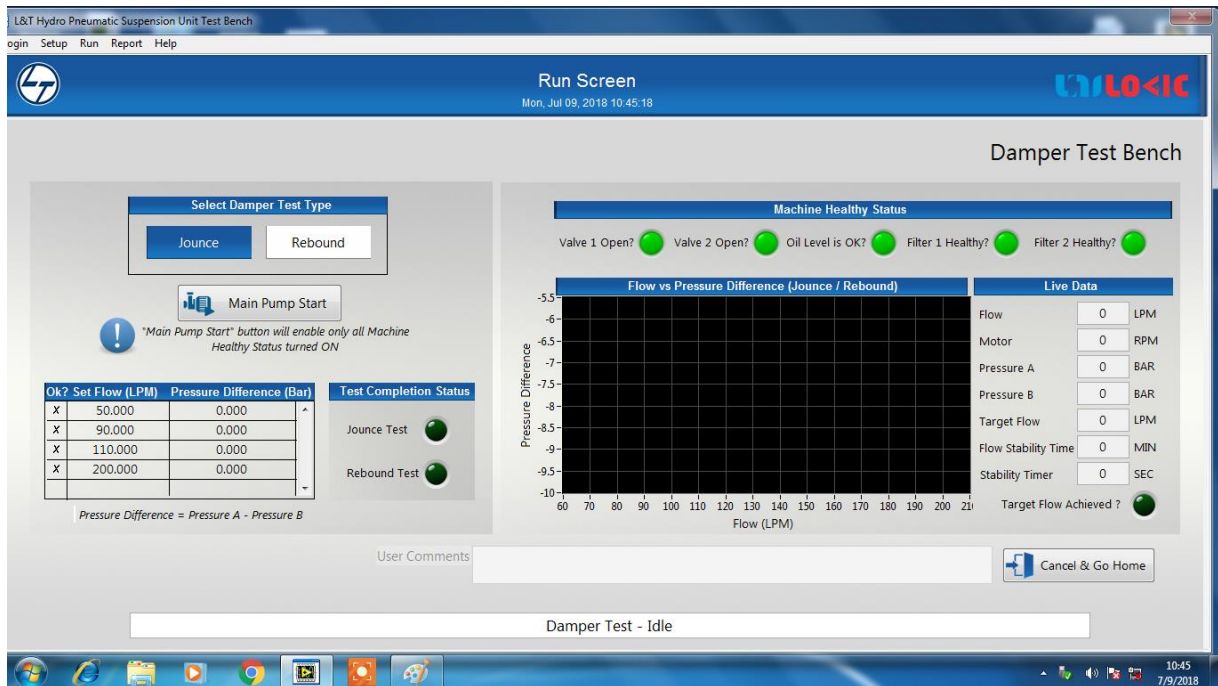

- Switch on the loading knobs, make sure red light over the damper power pack manifold turns red.

- Click on Main Pump Start.

Test will be done automatically, starting from jounce test and rebound test after that. Graph will be generated for both the sides and test report will be generated in the end.

SAFETY INSTRUCTION

User must ensure the following safety points before operation the test bench:

1. Ensure the main ball valve at pump inlet is always on; otherwise pump will get destroyed if run dry.
2. Pressure regulator setting must not be altered without proper supervision. It should not be more than 110 bar in any case.
3. Make sure bolts of the damper component are tightened properly.
4. Ensure the level of oil should be above the desired level. In automatic operation, level switch will shut the system.
5. In any case temperature of oil should not go beyond 50 degree Celsius.
6. Ensure the direction of the motor rotation is according to the sign.
7. As automatic test start, do not come nearby to the test bench.
8. Maximum value of the power pack pressure regulator should not be altered without proper supervision.
9. If any shot circuit happens, directly cut the main supply to the DAMPER test bench from VFD panel.
10. Ensure proper Earthing to the machine.



CAUTION !

Don't touch electric open point inside the machine
When machine is in running mode.

MAINTENANCE & TROUBLESHOOTING

T1. Power pack supply is not ON.

**S1: Make sure the main supply to the power pack is ON.
Check for Internal connection in the panel.**

T2. Motor is not getting ON from the DAQ panel.

S2: Make sure the Local/DAQ knob is on DAQ only.

T3. Pump is not making pressure.

S3: Make sure pressure regulator is not altered, or set the desire pressure from the regulator.

T4. Analog Input is not coming in the DAQ system.

S4: Make sure the MCB of the DAQ panel is ON.

T5. Flow is not coming in the flowmeter.

S5: Check both the loading valve are engaged.

T6. Filter is chocked(filter clogged light is ON).

S6: Check the Filter Code, And contact Neometrix to arrange for the filter element. (Waring: Do not operate the test bench without checking every filter, or else it will effect the Servo valve performance and might cause permanent damage).

T7. Leakage from fitting and hose connections.

S6: Properly tighten the fitting from where the leakage is there. Check for the hose.