

THIS DWG IS SOLE PROPERTY OF NEOMETRIX ENGINEERING PVT. LTD. UNAUTHORISED USE OF THIS DWG OR MAKING PRODUCT AS PER THIS DWG. WITHOUT OUR PERMISSION OR ANY OTHER MISUSE IS NOT PERMITTED.

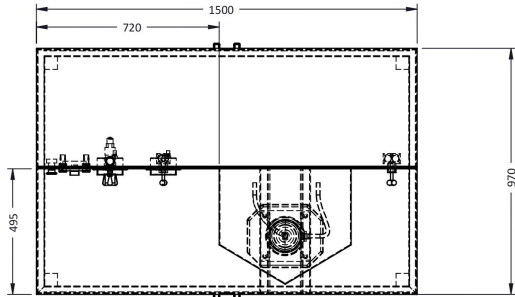

TOP VIEW

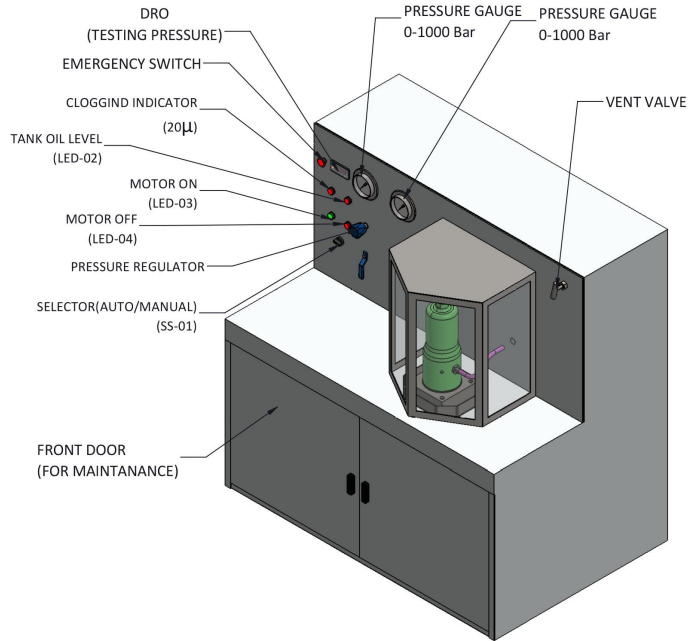

ISOMETRIC VIEW

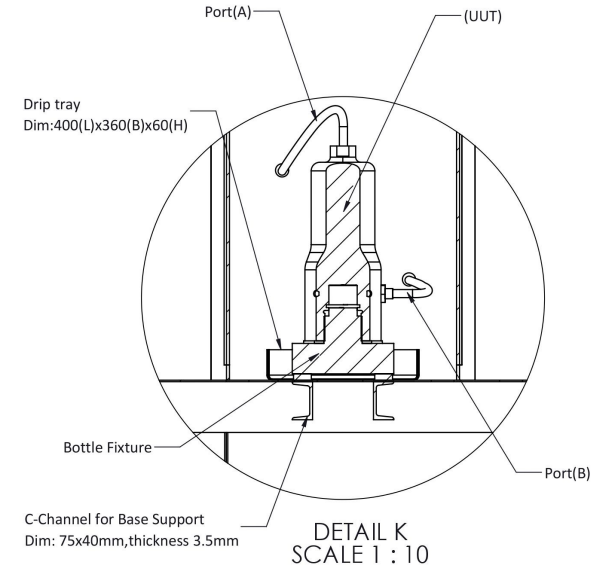

DETAIL K SCALE 1 : 10

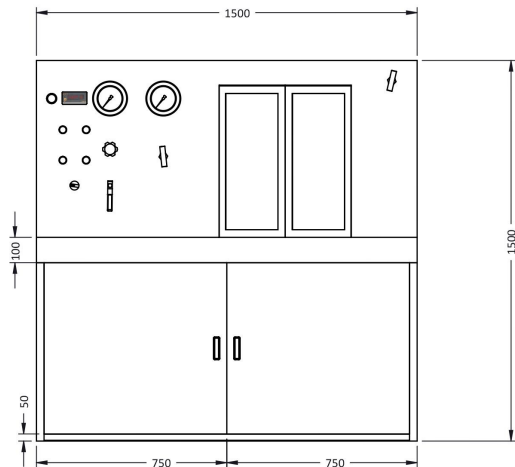

FRONT VIEW

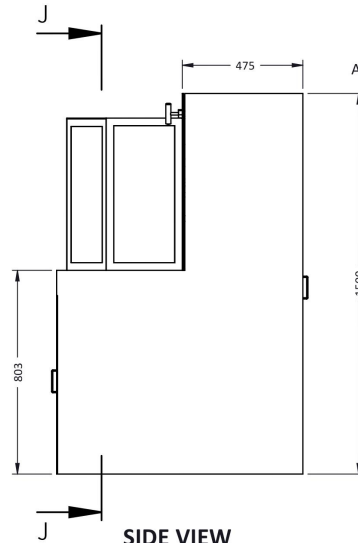

SIDE VIEW

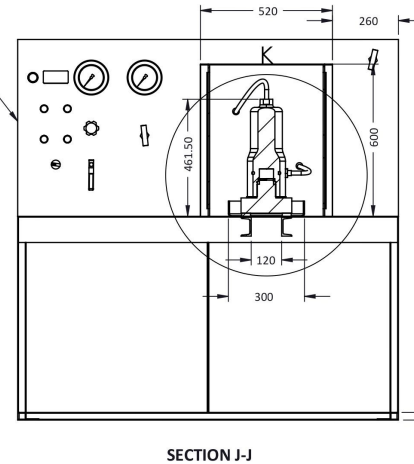

SECTION J-J

Part Table	
Description	Part No.
Test Stand	NX-A1782-PPTS-TS-01
Safety Chamber	NX-A1782-PPTS-SC-01
Pressure Gauge	NX-A1782-PPTS-PG-01
DRO	NX-A1782-PPTS-DRO-01
Indicator-01	NX-A1782-PPTS-LED-01
Indicator-02	NX-A1782-PPTS-LED-02
Indicator-03	NX-A1782-PPTS-LED-03
Indicator-04	NX-A1782-PPTS-LED-04
Selector Switch	NX-A1782-PPTS-SS-01
Vent Valve	NX-A1782-PPTS-VV-01
Dip Tray	NX-A1782-PPTS-DT-01
Bottle Fixture	NX-A1782-PPTS-BF-01

PROOF PRESSURE TEST BENCH

NOTE:
All Dimensions are in mm.

		NEOMETRIX ENGINEERING PVT LTD E-148, Sector-03, Noida, UP-201301 Tel No. : 0120-4100000 Fax No. : 0120-4100000 Email : contact@neometrixgroup.com			
		MAIN TITLE SUB - TITLE CODE CUSTOMER CONTRACTOR PO. NO.	HYDRAULIC TEST EQUIPMENT FOR HSU STATIC TEST BENCH A1782 _____ _____ -----	QA No. Cross Ref. Doc. No. Customer Dwg./Ref. No. Note:	REV
PROJECTION DRAWN BY & DATE CHECKED BY & DATE APPROVED BY & DATE	N.K S.H. S.P.S.	05/07/2018 05/07/2018 05/07/2018	Size Scale Sheet No./of NTS 01/01	NEO. DWG. No. T-DAP-A1782-GADWG-PPTS-TS	01