

THIS DWG. IS SOLE PROPERTY OF NEOMETRIX ENGINEERING PVT. LTD.  
 UNAUTHORISED USE OF THIS DWG. OR MAKING PRODUCT AS PER THIS DWG.  
 WITHOUT OUR PERMISSION OR ANY OTHER MISUSE IS NOT PERMITTED.

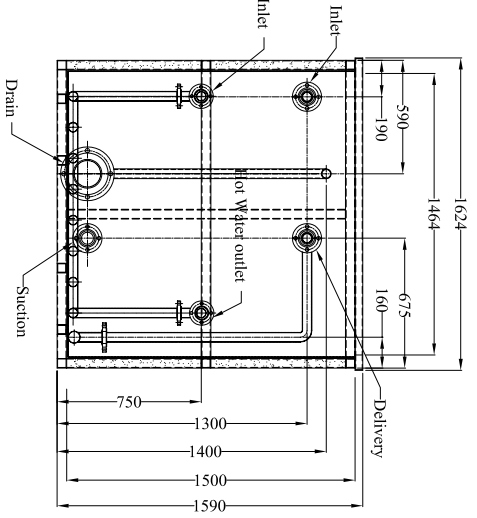
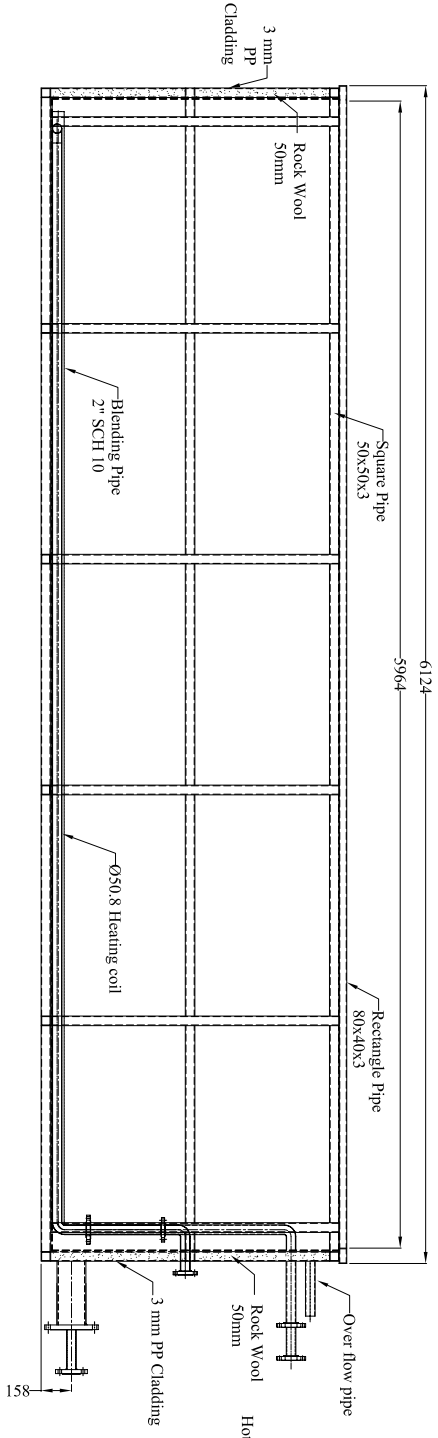
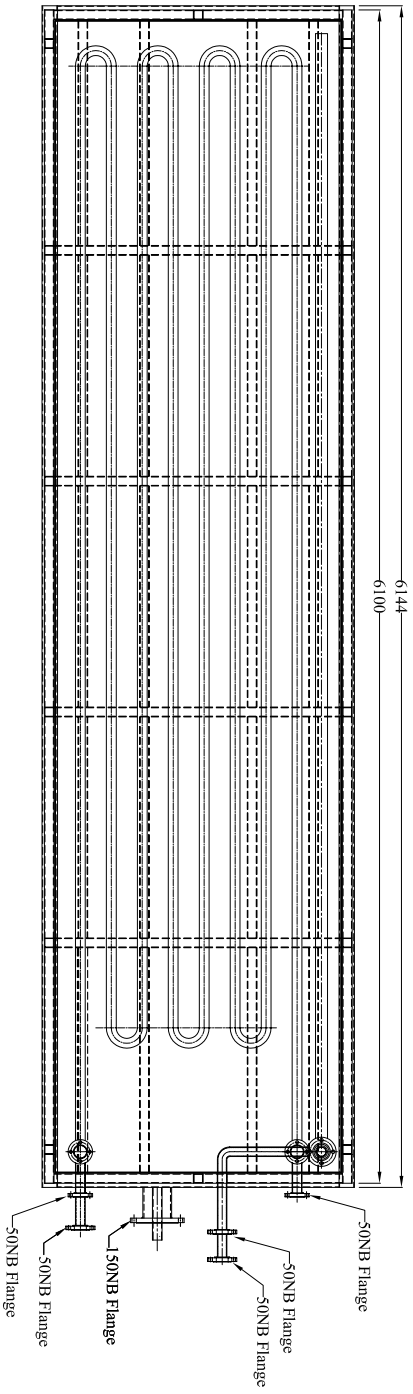

**ALKALINE TANK**  
**QTY-04 Nos.**

**NEOMETRIX**  
 www.neometrixtechnology.com

NEOMETRIX ENGINEERING PVT. LTD.  
 E-418, Sector-6, Noida, UP-201301  
 Tel. No:- 0120-4500888  
 Fax No:- 0120-4500888  
 E-Mail: neometrix@neometrix.com

MAIN TITLE: CHEMICAL CLEANING BAY  
 SUB-TITLE: ALKALINE TANK  
 CODE: A0752

CUSTOMER: HSL-VISHAKAPATNAM  
 END USER: HSL-VISHAKAPATNAM

APPLICATION: PRODUCTION  
 DESIGNED BY: K. S. SURESH  
 CHECKED BY: S. S. SURESH  
 APPROVED BY: S. S. SURESH

DATE: 10/11/10  
 SCALE: N=1  
 SHEET NO: 04  
 TOTAL SHEETS: 04

PROJECT NO: NS-AAD-2500818-STEP-4-18  
 REV: 06

**Note:-**

All Dimension are in mm.

